



CONOTEC CO., LTD.
DIGITAL TEMPERATURE CONTROLLER



FOX-2001

Instruction Manual



- A user manual for this product is posted on the company website.
- Please download the technical document and communications manual on the company website.

01 Safety precautions

Please read the safety precautions carefully for correct operation of the product.

- ※ The specifications and dimensions specified in this instruction manual may be changed without any notice for performance enhancement.

▲ Warning

1. This product was not made as a safe device. Therefore, this product should be attached with dual safety devices if it is used for the control purposes (e.g. a device vulnerable to accident and property damage, etc.).
2. Do not wire, inspect or service this product while the power is being supplied.
3. You must attach this product to a panel. Otherwise, it may cause an electric shock.
4. When connecting the power, you must check the terminal number.
5. Do not ever disassemble, process, modify or repair this product.

▲ Caution

1. Please make yourself familiar with all the operation instructions, safety precautions and warnings before using this product. Comply with related specifications and capacity requirements
2. Do not wire or install this product to any unit with high inductive load (e.g. motor, solenoid, etc.).
3. Use a shielded cable with a proper length when extending a sensor.
4. Do not use any part that generates an arc when used in the same power or directly switched in close proximity.
5. Keep the power cable away from a high-voltage cable and do not install this product in any place that is full of water, oil and dust.
6. Do not install this product in any place that is exposed to direct sunlight or rain.
7. Do not install this product in any place that is subject to strong magnetic power, noise, vibration or shock.

8. Keep this product away from any place that generates strong alkaline or acid substances. Use a separate pipe.
9. Do not sprinkle water onto this product for cleaning when installing it in the kitchen.
10. Do not install this product in any place where the temperature/humidity ratings are exceeded
11. The sensor cable should not be cut or cracked..
12. Keep the sensor cable away from a signal cable, a power cable or a load cable. Use a separate pipe.
13. Keep in mind that the follow-up service will not be available if this product has been arbitrarily disassembled and modified
14. ⚠ symbol on the terminal wiring diagram indicates a safety statement that alerts a warning or caution.
15. Do not use this product near any device generating strong high-frequency noise (e.g. high-frequency welding machine, high-frequency sewing machine, high-frequency radio, large-capacity SCR controller, etc.).
16. Using this product in any method other than those specified by the manufacturer may lead an injury or a property damage
17. The product is not a toy. Keep it away from children.
18. The product should be installed only by an expert or a qualified person.
19. The company will not be liable for any damage caused by the violation of the above warnings and cautions or by a consumer's fault

▲ Danger

Caution: Risk of electric shock

- Electric shock – Do not touch the AC terminal while the current is flowing. It may cause an electric shock.
- You must disconnect the input power when servicing it.

02 Model Types

Model	Sensor	Output	Temp.Range	Function
FOX-2001	NTC	Relay	-55.0°C ~ +99.9°C	TEMP. Control
FOX-2001S		SSR (12VPC 30mA Max)		

03 Components



- 1 Temp Output Lamp
- 2 Up Switch
- 3 Function Change Switch
- 4 Down Switch

[The Function of each key.]

1. : A key to change of the programs & setting temperature
2. : A key to change of the program's set values & temperature

04 Terminal Wiring diagram

[FOX - 2001]

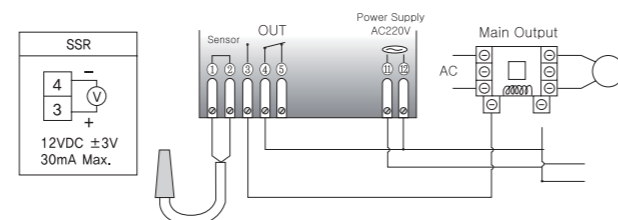

※ Output : When using over 250VAC 2A, be sure to use a power relay or magnetic contactor.

※ Exceeding the contact capacity may cause contact welding, poor contact, or relay damage, so please exercise caution

EX) SSR junction

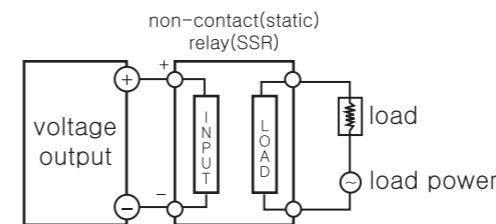

※ Please make sure that the SSR's capacity should be used more than load capacity.

EX) Relay junction

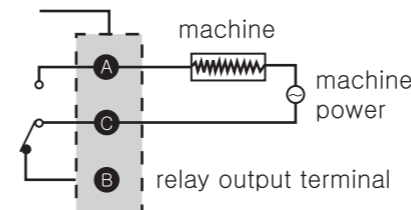

05 Setting process

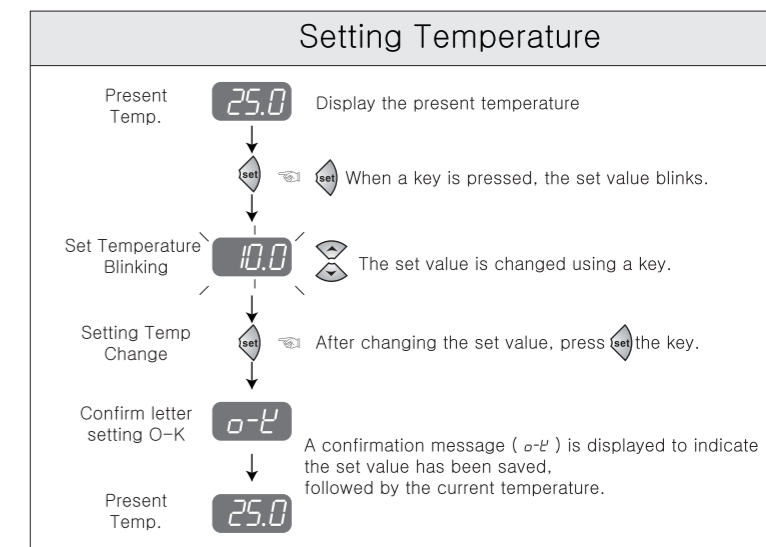

Program Setting (The value of each item is the factory setting.)

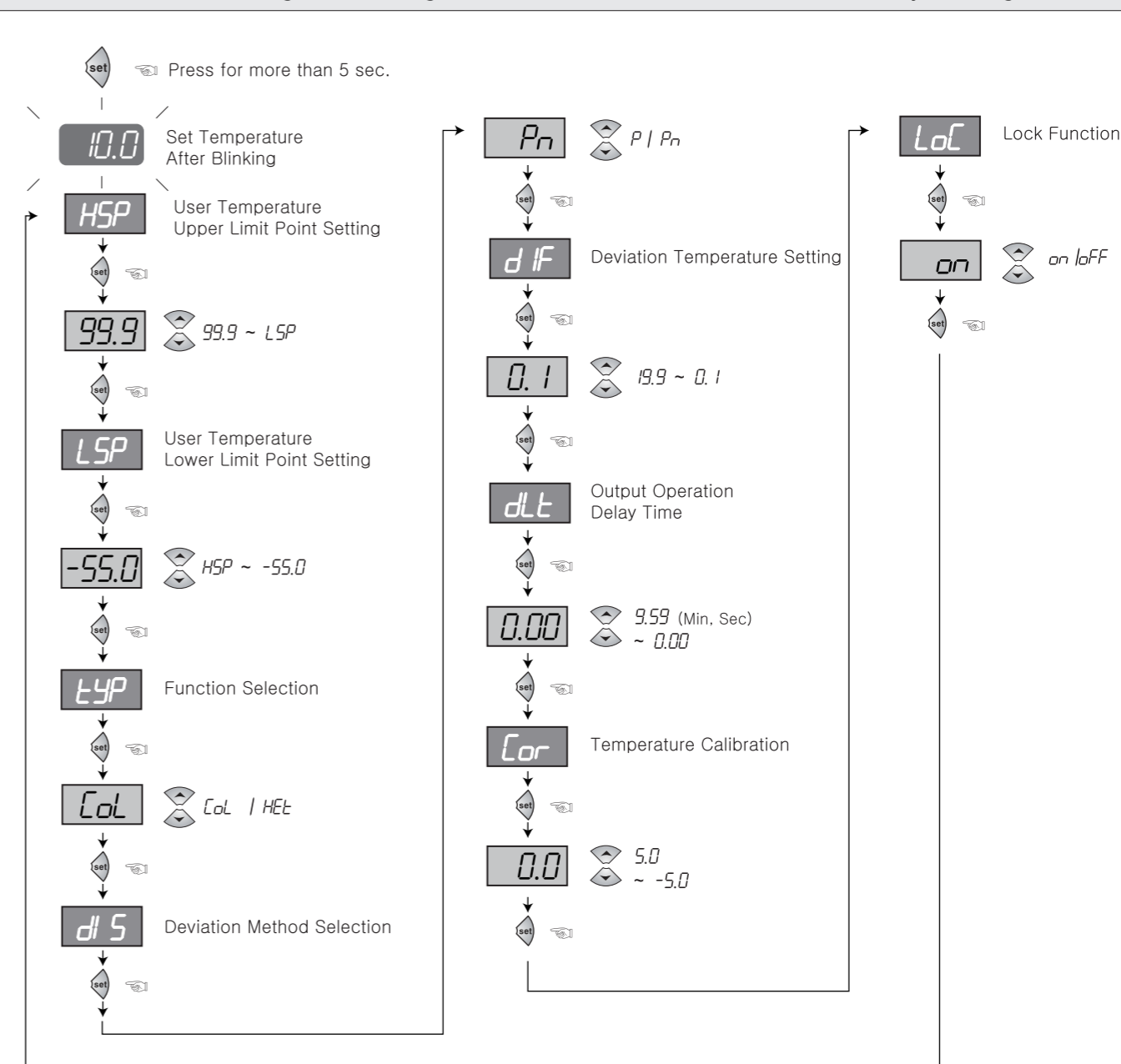

※ To change it with program mode, press the key for more than present temperature display mode.
 ※ The set or programming mode is terminated if you press the key for 2 second. parameters (set values) are saved after the display shows OK letter or return to present temperature automatically after 30 second.

06 Setting process

HSP : User Set Temperature Upper Limit (Maximum Setpoint Allowed for the End User)
The set temperature value cannot exceed the **HSP** set value
Example) **HSP** = 25.0°C Setting => The set temperature can be adjusted up to 25.0°C

LSP : User Set Temperature Lower Limit (Minimum Setpoint Allowed for the End User)
The set temperature value cannot be set below the **LSP** set value
Example) **LSP** = 10.0°C Setting => The set temperature can be adjusted up to 10.0°C

LYP : Cooling (CoL) and heating (HEt) selection functions

dF : Deviation Selection Method

P Output operation: Set deviation to + operation (off at the set point)

Example) Setting = 10.0°C, **LYP**:C, **dF**:5.0 Example) Setting = 10.0°C, **LYP**:H, **dF**:5.0

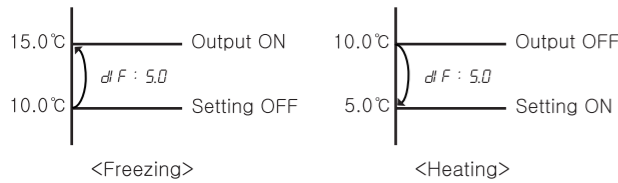

Pn Output operation: Set deviation to ± operation (based on the set point)

Example) Setting = 10.0°C, **LYP**:C, **dF**:5.0 Example) Setting = 10.0°C, **LYP**:H, **dF**:5.0



dF : Setting for temperature deviation

- In the ON/OFF control, it needs at regular interval between ON and OFF.
- By operating the ON/OFF control frequently, the relay or its output contact can be damaged quickly and it also occurs the hunting (oscillating, chattering) by virtue of external noise.
- You can make use of the temperature deviation in order to protect its relay or contact and so on.

• Output operation: Set deviation to + operation (off at set point)

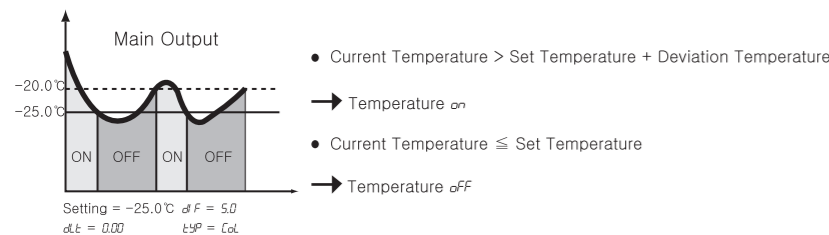

<When used for freezing>

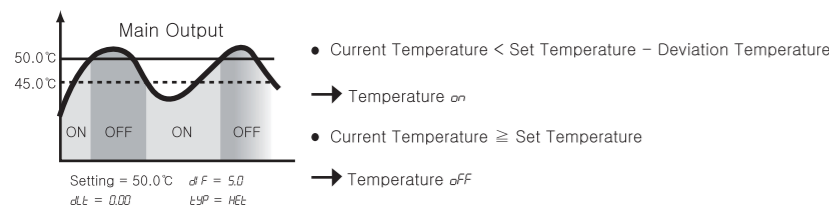

<When used for heating>

dL : Output Delay Time
- It is widely used as the followings in case of operating the ON/OFF control very often, (Cooler, Compressor and so on)
- To protect the operation machinery when re-input of the power supply or momentary stoppage of power supply.

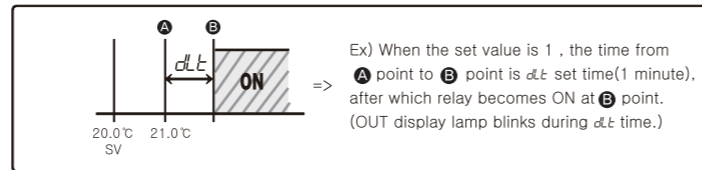

Cor : Current temperature calibration function

- While there is no problem in the product, a function to calibrate when temperature is different error and reference standard that occur in the input sensor (e.g. Mercury thermometer or thermomete currently use, a temperature controller)

- Ex) Actual temperature : 10.0°C
Display window : 12.0°C
→ **Cor** Modification of 0.0 to -2.0
→ Displayed as 10.0 (corrected current temperature)

LoL : Locking of the setting

- Safety function intended to prevent anyone other than the main user from changing the settings
- If set at **on** : All the settings expect for the set temperature will be locked.
- If set at **off** : All the settings will be unlocked.

Example of thermostat usage

Example 1) What is the temperature and program setting when the heater is turned off at 30°C and tried to operate at 25°C?

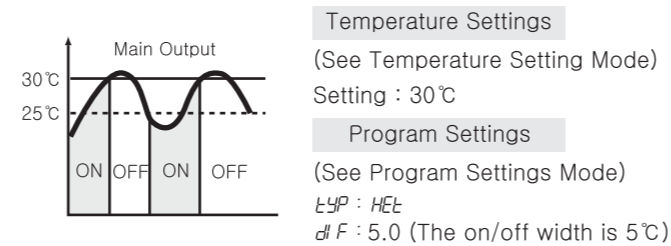

Example 2) What are the temperature and program settings when the cooler is turned off at 0°C and restarted at 2°C?

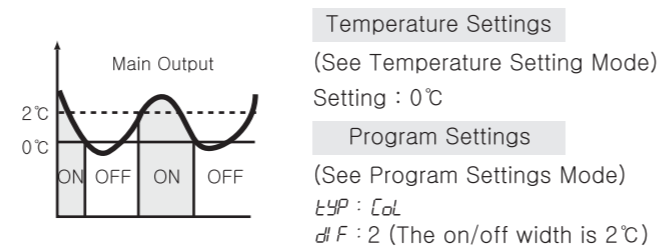

07 Dimension and panel hole sizes

(Unit : mm / error : ±0.5)

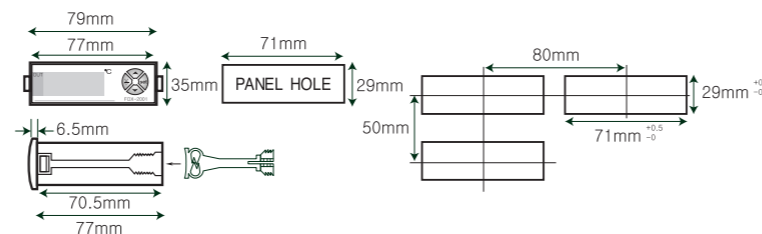

08 Easy Error diagnosis Instructions

※ If an error is displayed while the product is running

- **E-1** : It is case where the product was subject to a strong external noise and internal data memories have been damaged. In this case, contact us for product service.
- Although this controller was designed to withstand a certain level of external noise, it is not supposed to withstand all levels of noise.
- If the product is subject to a noise greater than 2KV, it could be internally damaged.
- If **o-E** (open error) or **s-E** (short error) is displayed, there is something wrong with a sensor. Please check the sensor.

※ The above specifications may be changed without any notice for performance enhancement. Please make yourself fully familiar with and follow the above precautions.

■ Warranty period: One year from the date of purchase

■ Address : (Street address) 56, Ballyongsandan 1-rp, Jangan-eup, Gijang-gun, Busan, ROK
(Land-lot address) 901-1, Ballyong-ri, Jangan-eup, Gijang-gun, Busan, ROK (46034)

- Product service : 070-7815-8289
- Customer service : 051-819-0425 ~ 0427
- FAX : 051-819-4562
- Email : conotec@conotec.co.kr
- SNS : Facebook, Instagram, Twitter, YouTube ▶ 'Search for 'Conotec'
- Website : www.conotec.co.kr

◆ Installation precautions

■ This device should be connected to a protective earth terminal and a power supply in order to prevent an electric shock.

■ Do not block the air outlet.

◆ Operation precautions

※ An operating environment of this device is as follows.

■ Ambient temperature : 0 ~ 60°C

■ Ambient humidity : 80%RH or less

■ Indoor uses only

■ Pollution class 2

■ Altitude under 2000m

■ Installation category : II

■ This device should be laid out in a way that its power cord is easy to handle.

■ Using this product in any method other than those specified by the manufacturer may damage its protection function

■ Major products and development

- Temperature/humidity controller
- Counter and timer controller
- Current and voltage panel meter
- Temperature/humidity indicator
- Oven controller
- CO2 controller
- PID controller
- Unit cooler controller
- Heat pump controller
- Chiller controller
- Thermo-hygrostat controller
- Short message alarm
- Temperature/humidity transmitter
- Smartphone app and monitoring system

※ This manual was prepared in the Naver Nanum fonts.